

ADR SWITCH COMPARISON SPECIFICATIONS

FEATURES	DPS			TSW (T SWITCH)					LOW VOLTAGE (BIG RED)			REDARC	
	DPS-1202	DPS-1202PP	DPS-2402	TSW12K	TSW12PK	TSW24K	TSW24VI	TSW24VEC	LV5010	LV5010K	LV5011	BMIS4PNV2KIT	BMIS4PPV2KIT
OPERATING VOLTAGE	12V DC	12V DC	24V DC	12V DC	12V DC	24V DC	24V DC	24V DC	12V DC	12V DC	24V DC	9-32V	9-32V
CONT. CURRENT RATING	300A	300A	300A	500A	500A	500A	500A	500A	200A	200A	200A	400A	400A
MAX. CURRENT RATING 5 SEC	2500A	2500A	2500A	3000A	3000A	3000A	3000A	3000A	500A	500A	500A	3500A	3500A
AUX. CIRCUITS N/O 10A (ALT. ISO)	1 x 10A	1 x 10A	1 x 10A	2 x 10A	2 x 10A	2 x 10A	2 x 10A	1 x 10A	2 x 10A	2 x 10A	2 x 10A	1 x 10A	1 x 10A
AUX. CIRCUITS N/C 10A	No	No	No	No	No	No	No	1 x 10A	No	No	No	No	No
ALT. ISOLATION D+ TO EARTH OPTION	Yes	Yes	Yes	No	No	No	No	No	No	No	No	No	No
SWITCHING POLARITY	POS-NEG	POS-POS	POS-NEG	POS-NEG	POS-POS	POS-NEG	POS-NEG	POS-NEG	POS-NEG	POS-POS	POS-NEG	POS-NEG	POS-POS
REMOTE SWITCHING	On/Off	On/Off	On/Off	Off	Off	Off	Off	On/Off	Off	Off	Off	Off	Off
LOW VOLTAGE MONITORING	Yes	Yes	Yes	No	No	No	No	No	No	No	No	No	No
10 SEC. DELAYED NEG. OUTPUT (300MA MAX)	Yes	Yes	Yes	No	No	No	No	No	No	No	No	No	No
MODE OF OPERATION	Electric	Electric	Electric	Elec/Mech	Elec/Mech	Elec/Mech	Elec/Mech	Electric	Elec/Mech	Elec/Mech	Elec/Mech	Elec/Mech	Elec/Mech
SWITCH IP RATING	IP65, IP67 & IP6K9K	IP65, IP67 & IP6K9K	IP65, IP67 & IP6K9K	IP67	IP67	IP67	IP67	IP67	IP66	IP66	IP66	IP66, IP67 & IP69K	IP66, IP67 & IP69K
Lockable	Yes	Yes	Yes	Yes	Yes	Yes	Yes	No	No	No	No	Yes	Yes
Ex Compliance	ATEX	ATEX	ATEX	ATEX	ATEX	ATEX	ATEX	ATEX	No	No	No	No	No

DPS

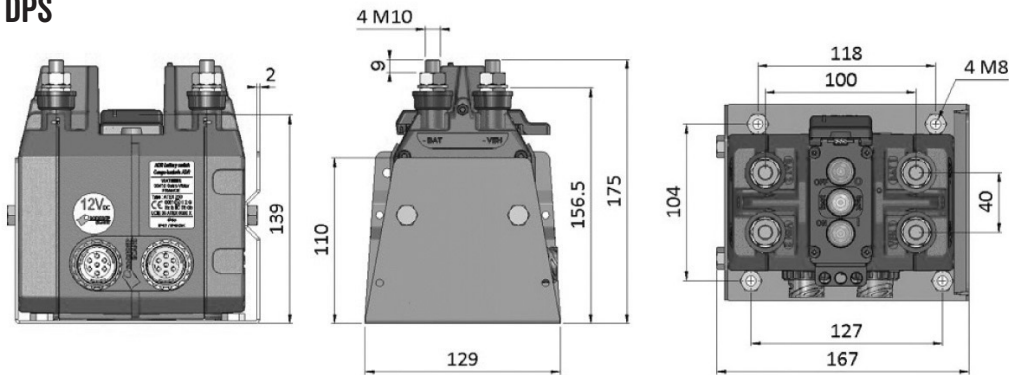

TSW (T SWITCH)

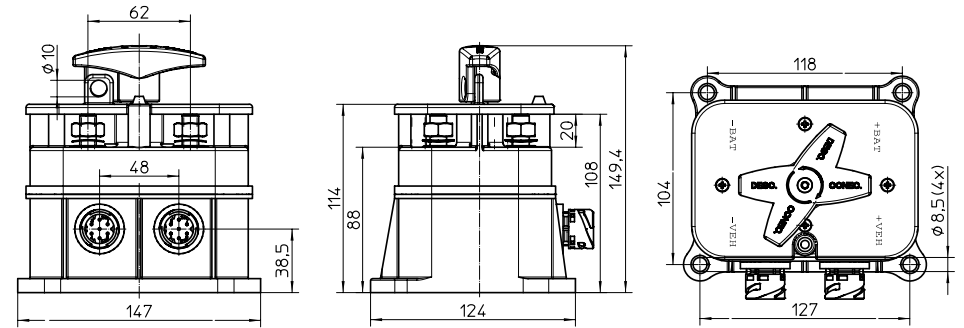

LOW VOLTAGE (BIG RED)

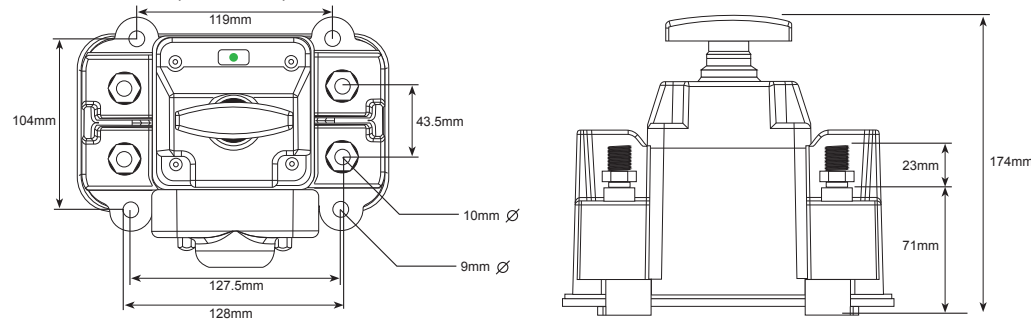

REDARC BMIS

