

Baxters

Installation & Specification Manual

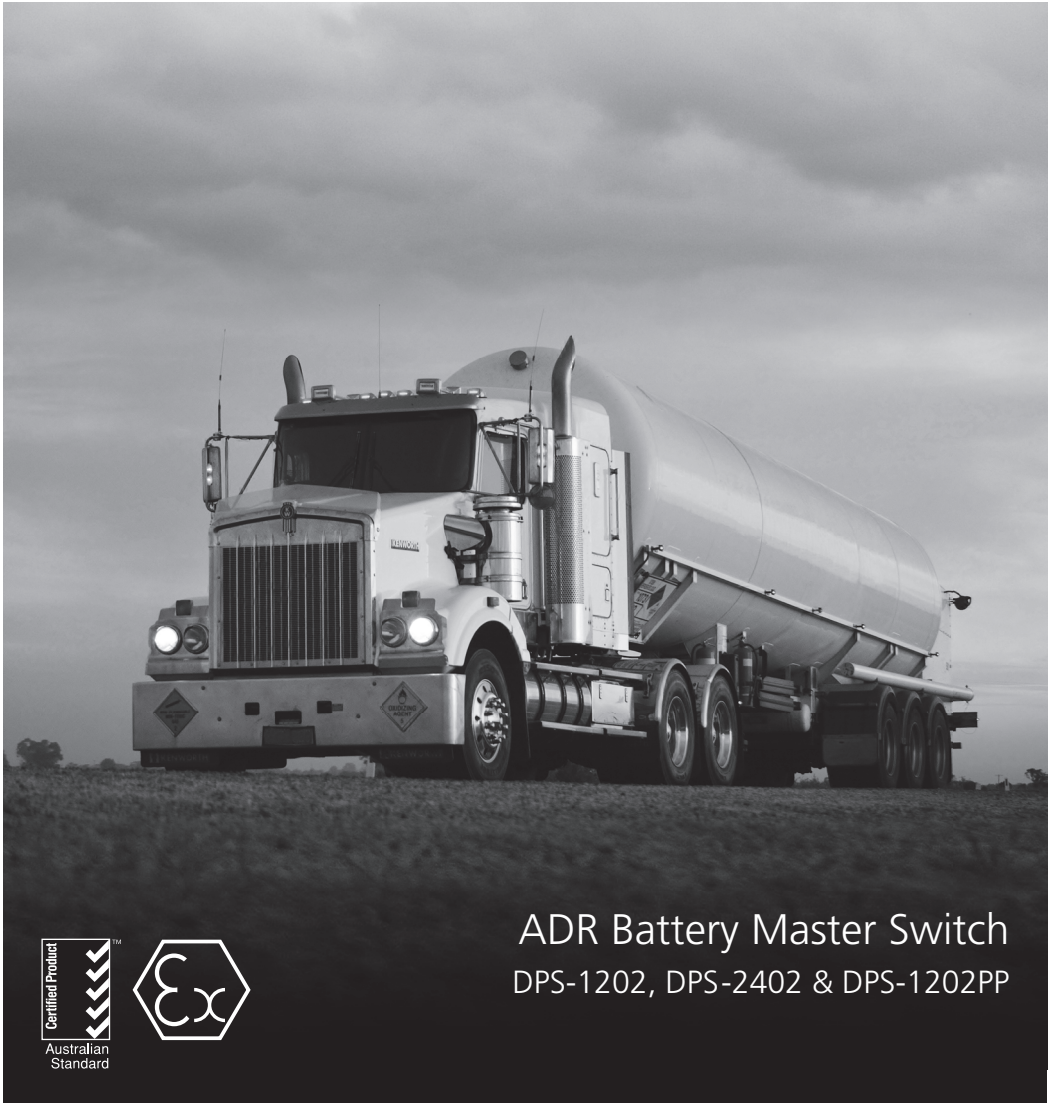

Australian
Standard



ADR Battery Master Switch
DPS-1202, DPS-2402 & DPS-1202PP

Table of Contents

Battery Switch Overview	1
Characteristics.....	1,2
Mechanical	2
Mounting.....	3
Electrical	4
Rating.....	5
Connector# 1	6
Connector# 2	7
Basic Installation	8
Alternator Field Isolation	9/10/11
External Switching.....	12
Voltage Monitoring	13
ECM Delay Control.....	14
“iROS” Roll Over Device.....	15
Liquip Roll Over Device.....	15
Control Panel	16
DIN Connector	17
Electrical Diagram	18
Environment Specifications.....	18
Optional Equipment	19
Replacing Lucas Master Switch.....	20
Warranty Statement	21
Support.....	22

© **Baxters** 39-43 Deans Court Dandenong South Victoria Australia
Phone +61 3 9730 7000 Fax +61 3 9730 7065 www.baxters.com.au
Copyright © 2024 by Baxters. All rights reserved.

Other brands, products, or service names listed in this document are the trademarks or registered trademarks of their respective holders. The illustrations, information and specifications referred to in this manual were correct at the time of printing. However, Baxters reserves the right, subject to all applicable laws, at any time, at its discretion and without notice, to discontinue or change any specifications or the design of any product referred to herein. (Doc v.1224 Issued December 2024)

The DPS-1202 (12 Volt) and DPS-2402 (24 Volt) Battery Master Switch have been designed to comply with Australian Standards AS 2809.2 and European ADR 2005. The DPS-1202 and DPS-2402 are a 2 Pole Bi-stable electro-mechanical relay switch with mechanical locking. It also incorporates Printed Circuit Boards (PCB) to monitor and operate several additional functions, many previously unavailable on older style battery isolator switches.

The prime function of the DPS-1202 and DPS-2402 is to disconnect and isolate the main battery positive and negative circuits of the vehicle or engine plant to render it safe and/or inoperable. You are offered several options to operate the switch; it may be operated directly at the control panel on the switch face, it can also be operated by means of a control switch located in the drivers' cabin or additional control switches at desired locations around the vehicle.

In EMERGENCY SHUT DOWN situation, such as in the event of a roll over the DPS-1202 and DPS-2402 switches will disconnect all power immediately via the emergency shut down switch or via a Roll Over Device.

In NON EMERGENCY SHUT DOWN situations, the Battery Master Switch will step through a preprogrammed shut-down, which after a 10 second delay, enables the safe disconnection of on board engine management systems to avoid data corruption. Incorporated in the non emergency shut down is Alternator field isolation to ensure that the alternator has been shut down prior to the disconnection of the main battery supply. If the alternator is not adequately shutdown, damage to the alternator is likely to occur.

The switch features include-

- Ex & CE Certified.
- Complies with ADR2005
- Complies with AS 2809 (Draft)
- Field isolation for North American vehicles.
- D+ shutdown for European vehicles.
- Delayed ECM shutdown to prevent re programming.
- Direct plug in iROST™ roll over device - works with all other roll over devices.
- Roll over simulation test with status light.
- Luminous ON/OFF/ROLL OVER push button switches.
- Robust IP67 rated enclosure.
- Stainless Steel mounting bracket. (Lucas SSB interchangeable)
- Low battery voltage disconnect.
- Lockable cover.



Note: it is highly recommended that the installation of the DPS-1202 or DPS-2402 is performed by a qualified Automotive Electrician or Electrical Engineer.



03410 St Victor-France
ADR Battery Switch
Type : ATEX 250
CE 0081 Ex II 2 G
EEx ib II C T6
LCIE 05 ATEX 6050 X/01
EMC 95/54/EC
IP67

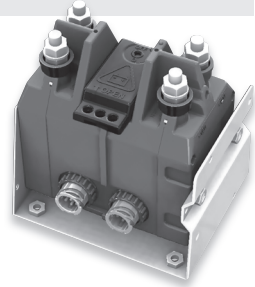

Mechanical

- Housing material: Reinforced PBT (Red) withstanding extreme environmental conditions.
- Mounting bracket and bolts: Stainless steel.
- Connection studs: Silver Plated copper.
- Size: approx. 160 x 100 x 170mm.
- Weight: approx 3.2kg.

Fitting

The Battery Master Switch should be fitted in accordance with State or Federal laws relevant to the application it is required to meet. Please refer to the appropriate governing authority for specific fitting requirements.

Note: According to ADR regulation 9.2.2.3

9.2.2.3.1- A switch for breaking the electrical circuits shall be placed as close to the battery as practicable. If a single pole switch is used it shall be placed in the supply lead and not in the earth lead.

9.2.2.3.2- A control device (not supplied see Optional Equipment 2.) to facilitate the disconnecting and reconnecting functions of the switch shall be installed in the driver's cab. It shall be readily accessible to the driver and be distinctively marked. It shall be protected against inadvertent operation by either adding a protective cover, by using a dual movement control device or by other suitable means. Additional control devices may be installed provided they are distinctively marked and protected against inadvertent operation. If the control device(s) are electrically operated, the circuits of the control device(s) are subject to the requirements of 9.2.2.5

9.2.2.3.3- The switch shall have a casing with protection degree IP67 in accordance with IEC Standard 529

9.2.2.3.4- The cable connections on the switch shall have protection degree IP54. However, this does not apply if these connections are contained in a housing which may be the battery box. In this case it is sufficient to insulate the connections against short circuits, for example with a rubber cap.

9.2.2.4- The battery terminals shall be electrically insulated or covered by the insulating battery box cover. If the batteries are not located under the engine bonnet, they shall be fitted in a vented box.

Mounting Position

The mounting bracket offers the same interface as the Lucas 196A (SSB).
Use 4 x M8 bolts for fixation. The welded nuts are part of the bracket.

The DPS Master Switch is an electric device. **Ensure it is NOT installed in areas that are prone to either direct pressure washing or excessive water ingress from moving vehicles (such as low to the ground, between wheels etc.)** Note: Refer Page 18 for Environment Specifications and further Installation notes.

- Maximum Tightening torque: 14 N.m
- It is strongly recommended to add locking nuts or thread locking adhesive to secure fastening. (Not Supplied)
- 2 mounting axis are allowed:
- Thru-bolts to be tightened to a maximum torque of 6 N.m.
Over tightening may cause housings to crack and void warranty.

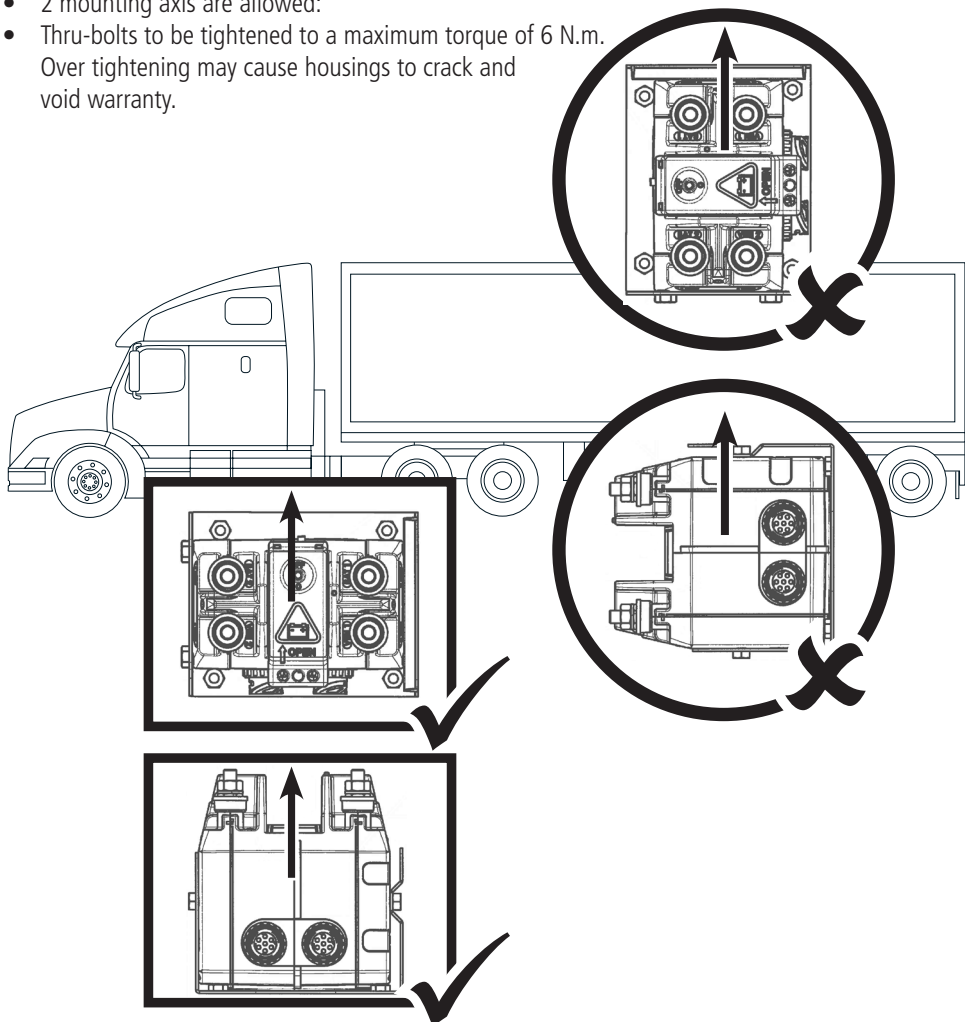

The Battery Master Switch is used for the disconnection of both positive and negative terminals of the battery. (Compliant with ADR 2005 regulation)
The positive circuit disconnects first.



Warning: Damage may occur if connected incorrectly.
Warning: Do not conduct welding to a vehicle while DPS-1202 or DPS-2402 battery master switch are fitted and connected to it.

- Main terminals: 4 x M10 studs. Use ring terminals for the cable connections positive caps.
- Tightening torque: 14 Nm.
- Carefully respect the polarity marked on the Battery Switch housing:
+BAT = Red Terminal = Positive terminal of the battery.
-BAT = Blue or Black Terminal = Negative terminal of the battery.
External connections to Battery Master Switch via 2 DIN connectors:

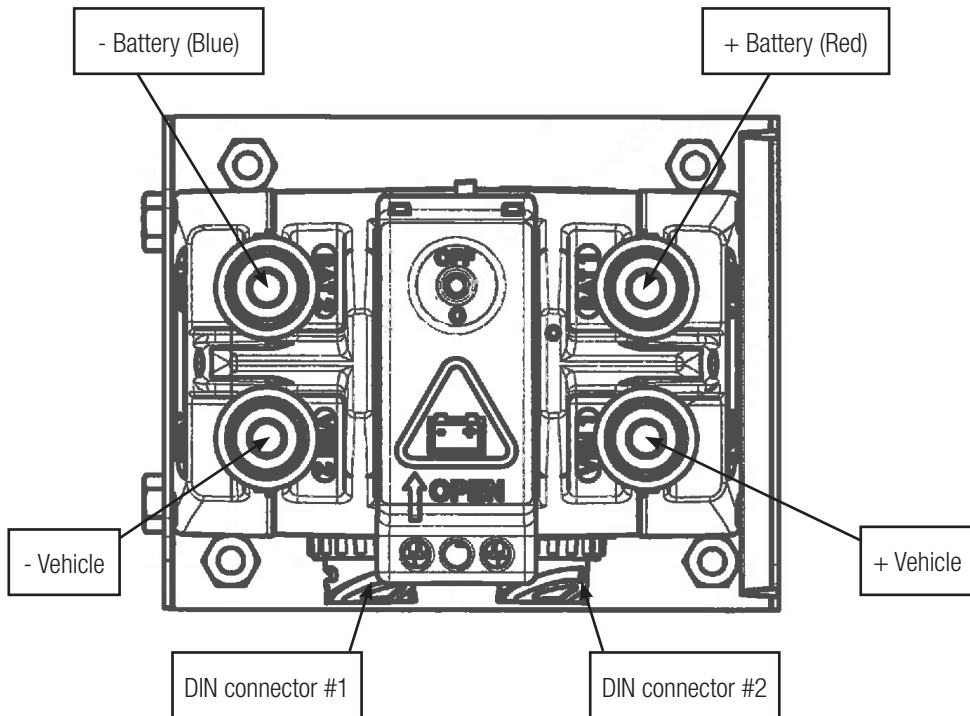

	DPS-1202	DPS-2402
Operating Voltage (Note 1)	9 to 15 volts	18 to 30 Volts
Current Rating	300 Amps continuous	300 Amps continuous
Max Current 5 Sec	2500 Amps	2500 Amps
Max Current 30 Sec	600 Amps	600 Amps
Field Isolation Circuit	10 Amps max	10 Amps max
Optional Low Voltage Monitoring (Note 1)	<11.4 Volts \pm 0.3V (60 sec delay)	<22.5 Volts \pm 0.3V (60 sec delay)
Low Voltage Disconnect (Note 1)	<9.5 Volts (60 sec delay)	<18 Volts (60 sec delay)
External Trigger	10mA	10mA
Roll Over	1 Amp	1 Amp
Current Draw OFF mode	150mA (red LED Illumination)	150mA (red LED Illumination)
Auxiliary relay # 1 (Note 2)	10 Amps	10 Amps
Auxiliary circuit # 2/ECM Delay (Note 3)	300 mA	300mA

(Note 1) See information Battery Voltage Monitoring (Page 13)



(Note 2) This circuit (change-over relay #1) switches immediately after the control switch is operated, then the main circuits open after >30 millisecond delay.

(Note 3) This circuit switches OFF after a 10 second delay when the main circuits are open.



In case of emergency (Only via Roll Over Device) all auxiliary and main circuits are disconnected immediately without delay.

While in the ON position the green push button of the control panel will remain illuminated.

Connector #1 (Grey or Black) for control circuit & auxiliary circuit:

	Description
Pin 1	<p>Grounded (- BAT) negative controlled output. Current limited. 300 mA Max External Fuse Recommended. This output is deactivated 10 second after the main circuits opening. (see notes ECM Delay P14)</p> <p> NOTE: This 10 second delay can be over ridden if the Master switch is turned OFF using the negative from location- Pin 2 / Connector 2</p>
Pin 2	<p>"+" Battery Positive supply output.</p>
Pin 3	<p>Battery Master Switch "OFF" trigger. This is used in conjunction with Pin 7/ Connector 1 to turn the Battery Master Switch via remote push button switch to turn the Battery Master Switch OFF.</p>
Pin 4	<p>Battery Master Switch "ON" trigger. This is used in conjunction with Pin 7/ Connector 1 to turn the Battery Master Switch via remote push button switch to turn the Battery Master Switch ON.</p>
Pin 5	<p>Field Isolation Circuit. This Pin has two functions to accommodate. (For both the American type and European type of Alternator field isolation) European Isolation: This pin is connected to the D+ on the alternator. When the Battery Master Switch is switch OFF this pin is switched to ground. American Isolation: When used in this type of field isolation, it is used in conjunction with Pin 6 / Connector 1 to cut field current. (Return only)</p> <p> NOTE: Caution is needed when connecting this Pin for the American type field isolation. If connected around the wrong way it can cause the alternator to keep charging in a Full Field Situation.</p>
Pin 6	<p>Field Isolation Circuit. This pin is used in conjunction with Pin 5 / Connector 1 for the American Style Field Isolation. (Positive)</p>
Pin 7	<p>Battery Master Switch common B+ Supply. This pin is used in conjunction with Pins 3 & 4 / Connector 1 to turn the Battery Master Switch ON & OFF. This pin cannot be used to supply power for anything else.</p>

Connector #2 (Green or Blue) for control circuit & auxiliary circuit:

	Description
Pin 1	Constant Battery negative output. Current limited to 1 Amp.
Pin 2	Battery Master Switch Emergency "OFF" trigger. This is a negative OFF only trigger and when used will override the time delay on Pin 2 / Connector 1.
Pin 3	Switched Battery Positive output. This pin is switched ON and OFF the same as the main contacts. It is limited to 1 Amp.
Pin 4	Warning Light test switch. When grounded this will illuminate the LED warning light marked "TEST" in the panel on the Battery Master Switch.
Pin 5	Positive output from test switch. This is a positive switched output from the TEST switch on the Battery Master Switch.
Pin 6	*For DPS-1202PP connect to Battery Negative B-. For all other models test switch Warning light out put. This is a direct connection to Pin 4 / Connector 2 and is used to operate an external warning light.
Pin 7 DPS-1202	<p>CONNECT TO + POSITIVE IGNITION SUPPLY. TO ACTIVATE VOLTAGE MONITORING: ONCE INSTALLATION IS COMPLETED AND BATTERIES ARE CONNECTED, PRESS RED AND GREEN BUTTONS SIMULTANEOUSLY FOR AT LEAST 5 SEC. (DEACTIVATION IS BY REMOVING BATTERY POSITIVE SUPPLY) WHEN INPUT PIN 7 IS CONNECTED TO + IGNITION SUPPLY ON THE VEHICLE, VOLTAGE MONITORING WILL BE DEACTIVATED DURING STARTING AND WHEN THE ENGINE IS RUNNING. TO DISABLE VOLTAGE MONITORING FUNCTION PERMANENTLY, PIN 7 NEEDS TO BE CONNECTED TO + POSITIVE BATTERY SUPPLY.</p> <p> IMPORTANT NOTE: If LVM is activated and pin 7 is not connected to a positive supply the Battery Master Switch automatically switches OFF if the battery voltage is less than 11.4 volts $\pm 0.3V$ (12V version) for 1 minute continuously. This prevents the battery from complete discharge during extended periods with electrical loads on and engine not running. In the event of continual voltage loss, the DPS Master switch will disengage at 9.5 Volts (12 Volt Version) regardless of the status of LVM (activated or de-activated) This second voltage threshold cannot be overridden or adjusted.</p>
Pin 7 DPS-2402	<p>CONNECT TO + POSITIVE IGNITION SUPPLY. TO ACTIVATE VOLTAGE MONITORING: ONCE INSTALLATION IS COMPLETED AND BATTERIES ARE CONNECTED, IN SEQUENCE PRESS GREEN AND THEN RED BUTTONS AND HOLD SIMULTANEOUSLY FOR AT LEAST 5 SEC. (DEACTIVATION IS BY REMOVING BATTERY POSITIVE SUPPLY) WHEN INPUT PIN 7 IS CONNECTED TO + IGNITION SUPPLY ON THE VEHICLE, VOLTAGE MONITORING WILL BE DEACTIVATED DURING STARTING AND WHEN THE ENGINE IS RUNNING. TO DISABLE VOLTAGE MONITORING FUNCTION PERMANENTLY, PIN 7 NEEDS TO BE CONNECTED TO + POSITIVE BATTERY SUPPLY.</p> <p> IMPORTANT NOTE: If LVM is activated and pin 7 is not connected to a positive supply the Battery Master Switch automatically switches OFF if the battery voltage is less than or 22.5 volts $\pm 0.3V$ (24V version) for 1 minute continuously. This prevents the battery from complete discharge during extended periods with electrical loads on and engine not running. In the event of continual voltage loss, the DPS Master switch will disengage at or 18 Volts (24 Volt Version) regardless of the status of LVM (activated or de-activated) This second voltage threshold cannot be overridden or adjusted.</p>

The following information provides installation instructions for the DPS Battery Master Switch; it provides for all functions of the switch. It is not required to have all functions operational to operate the DPS Battery Master Switch.

The following instructions provide for the most basic installation and operation of the Battery Master Switch.

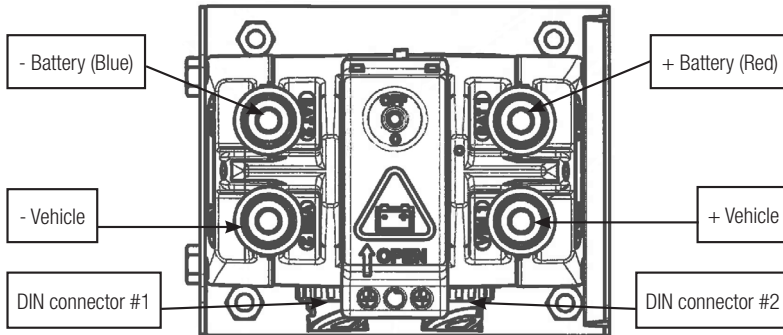

Battery Cable Installation

The 2 DIN Connectors supplied in the installation kit must be installed into connector 1 & 2 on the master switch. Each connector must be fitted with blanking seals (supplied) to ensure the IP Rating (weatherproofing) of the switch is not compromised. Failure to do so could allow water to ingress the Battery Master Switch, which will void the warranty.

		TOTAL CRANKING CIRCUIT LENGTH IN METRES									
System Voltage & Type	Maximum Circuit Voltage Drop Per 100 Amps	2.5m		5.0m		7.5m		10.0m		12.5m	
12-Volt High Output Heavy-Duty (4.5 - 7.8kW)	w/Single Path** to-and-from Starter (0.075 Volts)	00	000	In Parallel							
		0000 or 2-0	2-00	2-000	2-0000	2-0000 Positive Cables 2-0000 Negative Cables					
12-Volt Super Heavy-Duty (7.9 - 8.5kW)	w/Dual Path* to-and-from Starter (0.075 Volts (0.150 Per LEG))	00		000		0000 or 2-0		2-00	2-000		
		00		000		0000		In Parallel			
12-Volt Super Heavy-Duty (7.9 - 8.5kW)	Single Path** (0.060 Volts)	00	000	0000 or 2-0	2-00	2-000	2-0000	2-0000 Positive Cables 2-0000 Negative Cables			
	Dual Path* (0.120 per LEG)	00		000		0000		2-00	2-000	2-0000	
12-Volt Heavy-Duty (7.5 - 9.0kW)	0.20 Volts	6	4	2	1	0	00	000	In Parallel		
		0000 or 2-0		2-00							



NOTE: If the Battery Master Switch is to be turned off while the engine is running, it will be required to further install a circuit for Alternator Field Isolation. Isolating or de-energising the field system of the alternator avoids voltage peaks for open load when disconnecting the batteries.

Alternator Field Isolation Connection

European style Field Isolation

European style Field Isolation

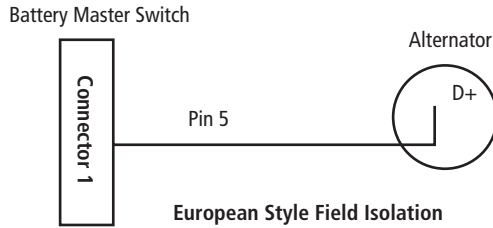

European style Field Isolation requires only one wire connection. Pin 5 of connector number 1 is required to be connected to D+ on the Alternator. This covers most of the European alternators but caution is required for later model alternators.

American style Field Isolation

American Style Field Isolation requires the field circuit to be opened circuited and a connection from these two circuits to return back to the Battery Master Switch.

American Field Isolation.

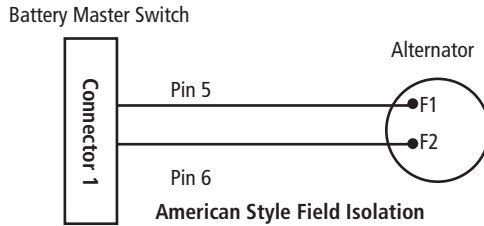

(Delco Remy 33/34 SI & Prestolite regulator 105-331)



When connecting a DPS Battery Master Switch, field isolation must be connected to the alternator in the correct manner. As illustrated by the figure 4.1.1 and 4.1.2 the alternator field terminals are to be wired in the manner indicated when connecting field isolation via connector # 1 Pin 5 (Return) & 6 (Positive).

NOTE: Caution is required when connecting the 2 wires, incorrect connection to the alternator can cause the alternator to charge full field cause damage to the regulator. Or result in internal damage to the battery isolation switch. It is highly recommended the alternator pin configuration is checked in case of previous modifications.



Prestolite regulator;105-331

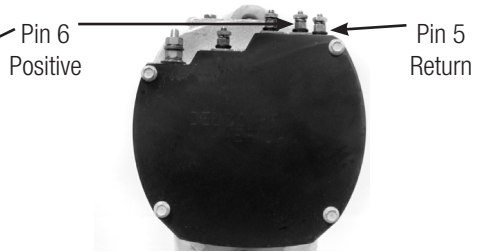

Delco 33/34S1 (Modified by Baxters)

Alternator Field Isolation Connection

European style Field Isolation - continued

	Negative Field Isolation	Positive Field Isolation
Regulator Side of Field Circuit	PIN 5	PIN 6
Field Side Of Field Circuit	PIN 6	PIN 5



Caution is required when connecting these 2 wires for field isolation, as it requires the wires to be connected the correct way. Failure to do so may result in the alternator going into full field situation or regulator damage when the Battery Master Switch is turned OFF while the engine is running.

Late Bosch Alternators

- Pin 1:** W – AC Output re tacho
- Pin 2:** L – Warning Light
- Pin 3:** 15 – Ignition
- Pin 4:** S – Battery Sense
- Pin 5:** DFM – Digital Field Monitor (output to ECM)

Cut ignition supply to Alternator Regulator terminal 3 and reconnect as per diagram below.

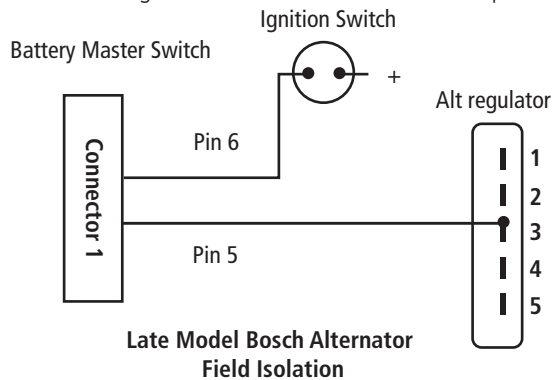

Alternator Field Isolation Connection

European style Field Isolation - continued

Late Type Alternators

Some of the later type alternators have an ignition supply to the alternator, including some European and Japanese alternators.

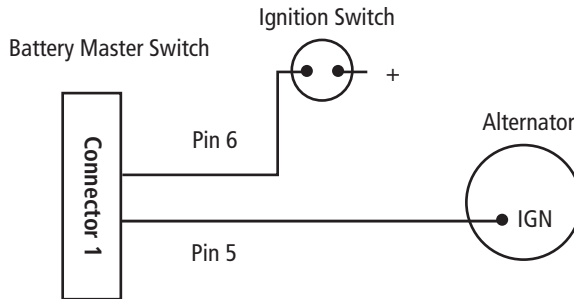

Late Style Alternator Field Isolation

It is required to open circuit the ignition supply to the alternator and ground the IGN terminal on the alternator. Correct Polarity is required here to ensure the ignition supply from the vehicle is not grounded inside the Battery Master Switch when it is turned OFF when the vehicle is running.

Important Note: All efforts are taken to provide accurate information, however it is advised the method is checked before final connection to ensure no problems or the manufacturer has altered the way the IGN supply to the alternator functions.

Battery Master Switch Alternator Field Isolation Relay

Field isolation connections are made by connecting the alternator field connections to Pin 5 or Pin 5 & Pin 6 on Connector 1. Below is the schematic of the field isolation relay which is integrated into the circuit board inside the Battery Master Switch. (Shown with relay in rest / off mode)

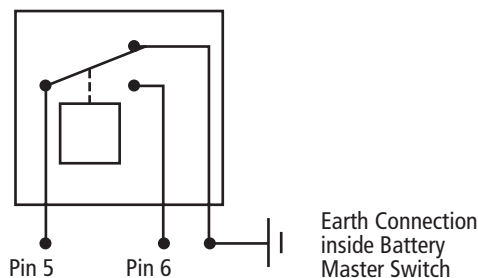

For fitment of optional remote mount switches

Connector 1

- Pin 3 – External OFF Activation
- Pin 4 – External ON Activation
- Pin 7 – External Switching Supply

A variety of wiring and switching options are suitable to control the Battery Master Switch. Additional switches in different locations can be connected in parallel. It is recommended that only additional OFF switches are added due to the complexity of keeping switches synchronized. The External switch can be used to turn the master switch OFF only.

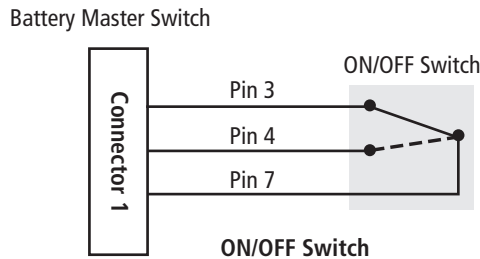
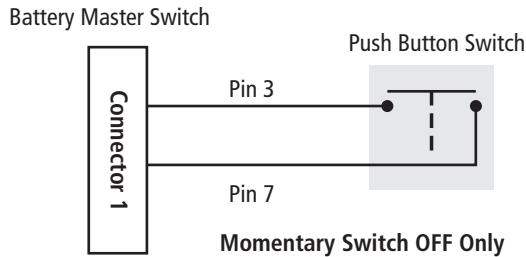

The off signal from any of the switches will override the ON signal. If the Battery Master Switch is turned OFF, the switch cannot be turned ON if any external switch is in the ON position.

Connector 2

The Battery Master Switch can also be turned OFF via PIN 2 Connector 2. This is an emergency negative shutdown that will override the 10-second delay on the Engine ECM output. This pin is commonly used for a roll over device but can be used for an immediate emergency shutdown of the Battery Master Switch.

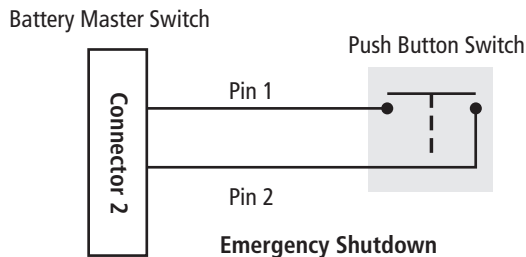

Connector 2 / Pin 7- The Voltage Monitoring circuit.

Battery Voltage Monitoring.

- TO ACTIVATE VOLTAGE MONITORING: ONCE INSTALLATION IS COMPLETED AND BATTERIES ARE CONNECTED, PRESS RED AND GREEN BUTTONS SIMULTANEOUSLY FOR AT LEAST 5 SEC. (DEACTIVATION IS DONE BY REMOVING BATTERY POSITIVE SUPPLY.)
 - When activated the DPS Battery Master Switch automatically switches OFF if the battery voltage is less than 11.4 volts $\pm 0.3v$ (12v Version) or 22.5 volts $\pm 0.3V$ (24V version) for 1 minute continuously. This prevents the battery from complete discharge during extended periods with electrical loads on and engine not running.
 - Permanently deactivated LVM - Connector# 2 pin 7 is connected to +supply.
 - Deactivate LVM during start and ignition ON - Connector# 2 pin 7 is connected to + ignition signal on the vehicle.
 - NOTE: The DPS Battery Master Switch has a second voltage threshold of 9.5 volts (12 Volt) 18 Volts (24 Volt) which cannot be overridden and will always be activated. The switch will automatically open after 60 seconds on continuous detection of a voltage below the threshold of 9.5V (12V version) or 18V (24V version). This ensures compliance with AS 2809 (Draft)
1. To permanently deactivate the Voltage Monitoring, Pin 7 must be connected to + Battery Positive supply of the vehicle.

Battery Master Switch

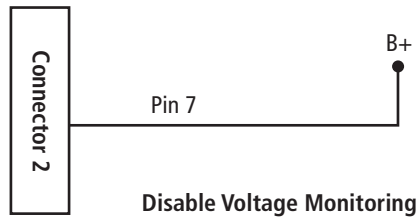

2. Deactivate LVM during start and ignition ON, Pin 7 must be connected to + Positive Ignition supply of the vehicle.

Battery Master Switch

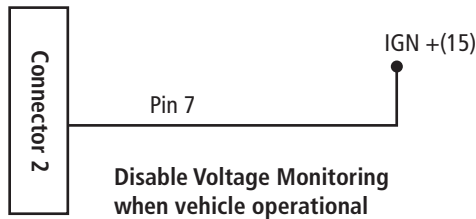

ECM Delay Control

The purpose of the ECM delay control is to supply power to the ECM for 10 seconds after the Battery Master Switch has turned OFF. Some engine computers become scrambled; if power is removed while the engine is still running. This can often result in the need for a service technician to reset the engine ECM.

The Battery Master Switch has a positive and negative output to control up to 2 relays, one relay for the positive and one for the negative supply to the engine ECM. The Battery Master Switch cannot directly power the ECM; it has a current limit of 300mA.

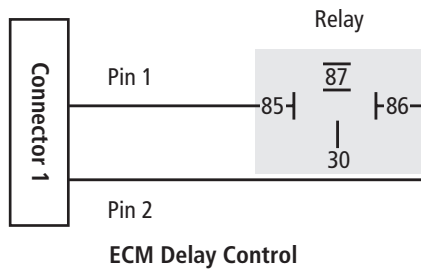

iROS Roll-Over Protection

Part Number: VRD12-24 (Multi – Voltage)

The iROS roll-over protection device is available from Baxters and can be mounted directly on DPS bracket.

Wiring designation iRos, Connector 2	
Pin 1	BLUE; iROS Module - Negative Supply
Pin 2	GREEN; iROS Module Emergency Shutdown Negative Pulse
Pin 3	BROWN; iROS Module Positive Supply
Pin 4	BLACK; iROS Module Warning Light Output
Pin 5	YELLOW; iROS Module Test Signal
Pin 6	WHITE; not used, spare for future product development
Pin 7	See note referring to Low Voltage Monitoring

CAUTION: This unit (like all electronics) is ESD (Static) sensitive. When working on exposed conductors (wires) ALWAYS wear ESD wrist /grounding straps and always work on ESD bench mat. It must be securely fastened. Please refer to the iROS documentation.

Two mounting possibilities for iROS:

Liquip Roll-Over Protection

Part Number: RS 400 (Multi – Voltage)

The LIQUIP roll-over protection device is available from Baxters and can be connected directly on the DPS Master Switch.

Wiring designation Liquip device, Connector 2	
Pin 1	GREEN/YELLOW & BLACK; LIQUIP Module Negative Supply
Pin 2	BROWN; LIQUIP Module Emergency Shutdown Negative Pulse
Pin 3	RED; LIQUIP Module Positive Supply
Pin 4	Not applicable
Pin 5	Not applicable
Pin 6	Not applicable
Pin 7	See note referring to Low Voltage Monitoring

Control Panel Features

- 1 x illuminated push-button ON switch –GREEN*
- 1 x illuminated push-button OFF switch –RED*
- 1 x illuminated push-button TEST switch for "iROS" module test- YELLOW

Each button is equipped with a clear silicon cap.

*Other remote push-buttons can be used outside: cab, chassis
(See Optional Equipment).

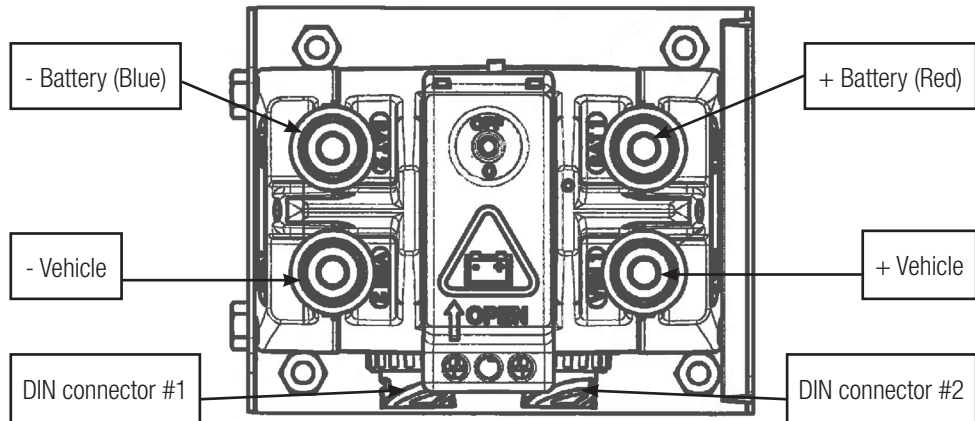

DIN Connector fitting instructions

When connecting conductors into DIN connectors, carefully observe correct installation of terminal and cable seals as illustrated below.

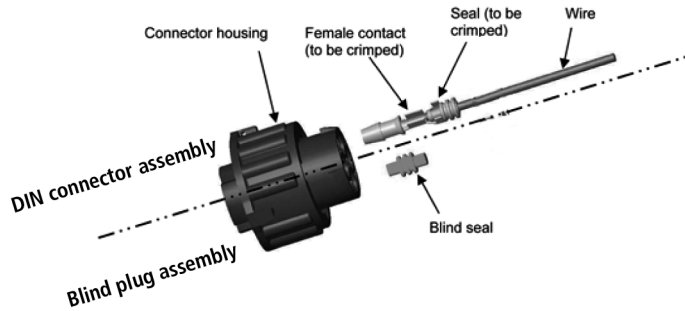

DIN Connector Fitting Kits

Electrical Kit Re-order Part Number: BMS-PKIT

- 2 x DIN Style Connector assembly 1 X Grey or Black, 1 x Green or Blue.
- 20 x Female (Receptacle) Contact Terminals
- 20 x Blue Wire seals.
- 2 x Terminal Retainer Locking tabs (supplied only for GHW connector)
- 12 x Blanking Seals.
- 4 x Battery Cable Protective Boots & Flat washers



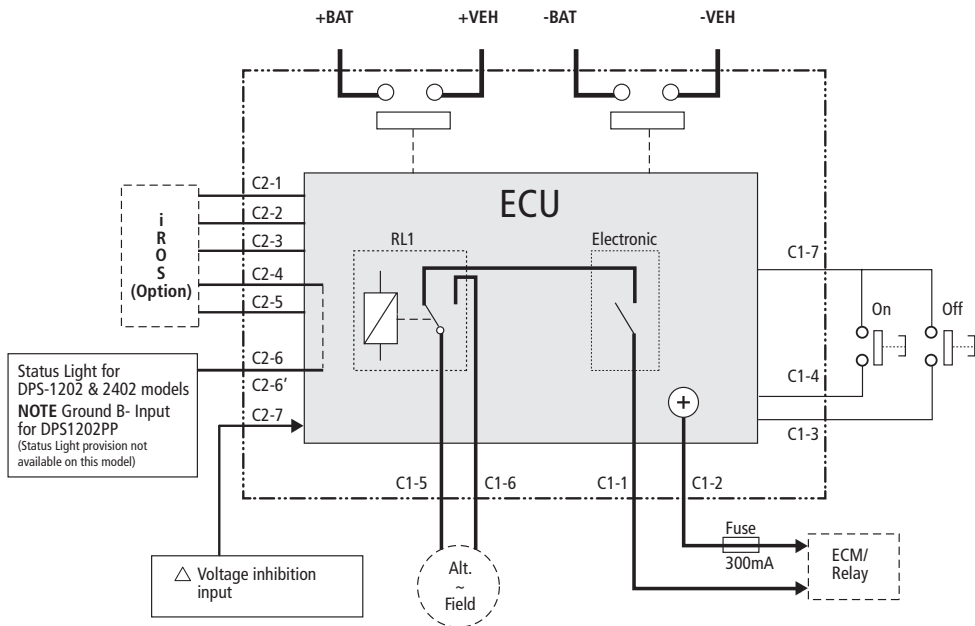

Environment Specifications

- Switches have a housing rating of IP67 minimum (IEC529 and ADR Requirement); (IP67- Protection from high pressure jets of water (up to 80 bar) from any angle.
 - Switch Terminals and Plugs must have a rating of IP54 minimum (ADR Requirement); (IP54-Solids: Limited dust ingress protection. Liquids: Protection against water spray from any direction). **Note Refer Paragraph 9.2.2.3.4 for exception on Page 2.**
 - The switch is environmentally rated at IP67, with exposed terminals and plugs at IP54, meaning water under high pressure from moving wheels or vehicle washing may penetrate the switch or plug gaskets if it is installed in undesirable locations. Like any electronic component, the switch and any external On/Off Emergency buttons are recommended to be installed in dry areas in or near the battery box and/or well away from the wheels and the road surface. Ensure the installation & specification manual is followed carefully and **ALL cable blanking glands are used and installed correctly if wiring options or the Roll Over Device Plug is not used.**
 - Temperature range: -40° to +85°C
 - Vibration resistance: IEC 60068-2-6, Test Fc, 5g (50-200Hz).
- See "Fittings-Mounting Positions."

Optional Equipment and Accessories

Emergency Stop Control Switch

A remote control device to facilitate the disconnecting and reconnecting functions of the battery switch shall be installed in the drivers cab. Other remote push – button may be installed outside, in parallel (e.g. chassis). The control switches shall be protected against inadvertent operations (e.g. cover)

Part No	Description.	Figure
SW-K174	Latching Switch Push On / Twist Off Double Pole IP67	1
SW-K174-G	Latching Switch Push On / Twist Off Double Pole with Guard IP67	2
SW-K175	Momentary Switch Push Button Single Pole IP67	1
SW-K175-G	Momentary Switch Push Button Single Pole with Guard IP67	2

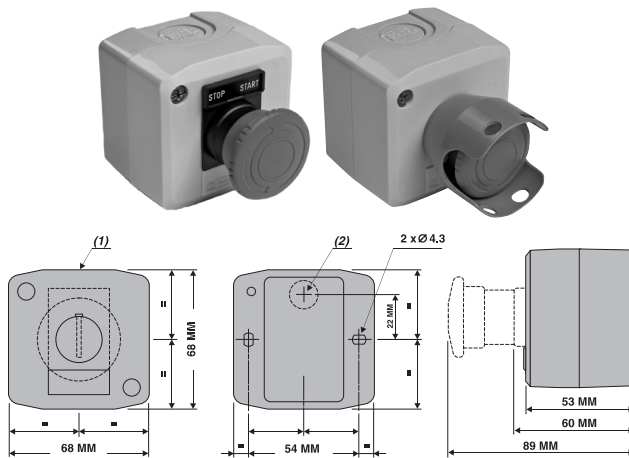

Description	Lucas Master Switch	DPS MASTER SWITCH	
Battery Positive	Pin 7	Bat+	
Battery Negative	Pin 9	Bat -	
Vehicle Positive	Pin 8	Veh+	
Vehicle Negative	Pin 10	Veh -	
Field Isolation	Pin 1	Connector 1 / Pin 5	
	Pin 3	Connector 1 / Pin 6	
External Shutdown		Positive Trigger	Negative Trigger
	Pin 2	Connector 1 Pin 7	Connector 2 Pin 1
	Pin 4	Connector 1 Pin 3	Connector 2 Pin 2
Vehicle Positive Output	Pin 12	Connector 1 / Pin 2 (Note 1)	
Battery Negative Output	Pin 11	Connector 1 / Pin 1	
Auxiliary Contacts	Pin 5	N/A (Note 2)	
	Pin 6	N/A (Note 2)	

(Note 1) This is a positive vehicle output, the same as the Lucas SSB Master Switch except that it is a current limited to 1 amp. It also has a 10 second delay when the master switch is turned off via the external shutdown on connector 1 or on the master switch itself.

(Note 2) There is not an internal set of contacts to directly replace these contacts. This is easily overcome by adding an external relay. This can be controlled by using either Pins 1 & 2 on connector 1 or using Pins 1 & 3 on connector 2.

Using the negative shutdown trigger allows for the 10 second delay on Pins 1 & 2 on connector 1. If using the positive trigger there will be no delay.

Handy Tips to Observe

1. Ensure Batteries are fully charged.
2. Ensure correct operation of starter motor.
3. Always ensure adequate cable size is used when installing a Battery Master Switch.
4. Always leave this installation and specification manual with the vehicle.
5. When a DPS Master switch has been switched off via a remotely mounted switch. It is required that all other switches be similarly switched OFF before the Master Switch will be capable of turning ON.

Warranty Statement

All products supplied by Baxters are warranted to be free of defects in materials and workmanship under normal use and service. The length of the warranty period may be determined by reference to the Warranty Period Schedule below.

The warranty period commences on the date of sale of the product by Baxters and is not transferable.

Note – warranty is void if manufacturers and or Baxters labels are removed or tampered with.

All claims under this warranty must be made within the relevant warranty period by returning the product to Baxters at the purchasers' expense accompanied by a properly completed warranty claim form together with evidence of purchase. Failure to provide the necessary information will result in denial of claim.

Compliance with these requirements is a fundamental pre-condition to the application of this warranty.

This warranty does not apply to failure or damage to a product caused by incorrect or faulty fitment, accidental or intentional damage, failure of other products, incorrect application or repair, contamination by foreign materials or modification carried out by anyone other than Baxters. Also excluded from this warranty are parts subject to normal wear (e.g. brushes).

All other warranties and implied terms as to fitness or quality of the products sold are expressly excluded except to the extent that they cannot lawfully be excluded.

Baxters liability pursuant this warranty (and any implied warranty or term which cannot lawfully be excluded) shall be absolutely limited to Baxters in its discretion either repairing or replacing the defective product or providing a credit or refund of its invoiced price and shall in no case include any consequential or other costs or losses or the costs of removal or refitting of any part.

The purchaser acknowledges that the purchaser has a specialised knowledge of the products supplied by Baxters and has ordered appropriate products and not relied on Baxters to advise or assist in the selection of products or their fitment or application.

This warranty supersedes all previous Warranty Policies issued for Baxters.

Warranty Period Schedule

Application	Months	Application	Months	Application	Months
Agricultural Equipment	6	Marine Engines	6	Passenger Vehicles	12
Construction Equipment	6	Material Handling Equipment	6	School Buses	6
Courier Vans	6	Medium and Heavy Trucks	12	Transit Buses	6
Industrial Equipment	6	Mining Equipment	6	Parts & Accessories	3

This agreement constitutes the entire agreement between Baxters and the purchaser with respect to the sale of products to the purchaser. All prices, items and conditions of sale are subject to alteration without notice.



Installation & Specification Manual



Support

Should you require any assistance with this product or any of the Baxters products please contact Baxters Monday through Friday, 8AM – 5PM EST

Baxters 39-43 Deans Park Court Dandernong South Victoria Australia

Phone +61 3 9730 7000 • Fax +61 3 9730 7065

Free Call Outside Metro VIC/NSW/SA/QLD/NT/TAS: 1800 621 068

Free Call Outside Metro WA: 1800 624 279

www.baxters.com.au

v.1224